



# 442 Field Mixer



## The Ultimate Portable Mixer for ENG, Production, and Film Sound

Developed with input from the industry's top audio engineers, Sound Devices 442 has the audio performance, feature set, and mechanical construction demanded by those who rely on audio gear for their livelihood. The 442 contains four microphone preamplifiers that re-define portable audio performance. Its comprehensive inputs and extensive outputs, including direct outputs per channel, are at home in small run-and-gun applications as well as large, multiple input productions.

The 442 incorporates high-efficiency power circuitry to run from either four internal AA batteries or external 5–18 VDC. All controls are accessible on its three main surfaces, there are no hidden functions. Its software-controlled output meter can be selected to display VU, PPM (peak), or combined VU/PPM ballistics.

The 442 is the centerpiece of Sound Devices growing line of professional audio products. Sound Devices products are designed to withstand the extremes of field production.

[www.sounddevices.com](http://www.sounddevices.com)

## KEY FEATURES

### Superb Audio Specifications

No compromising on audio performance no matter where production takes you.

### Variable Input Trim

Setting up a gain structure with any type of input is quick and easy.

### VU/PPM Metering Via Sunlight Viewable LED's

The industry's most informative level metering.

### Limiters Per Channel and Per Output Bus

Prevents overloading the camera or recorder. Set it and forget it.

### Direct Outputs per Channel

Designed for complex, multi-track recording environments.

### Customization Via User Setups

Access over 18 custom functions at the front panel.

### Three Separate, Isolated, Line-Level Outputs

Send to two cameras and a digital recorder without worry of signal interaction or ground problems.

### Two Stereo Returns

Monitor multiple cameras or camera plus IFB in headphones.

### Pop-Up Pots for Secondary Controls

Frees up the control surface for important controls.

### Durable, Light-Weight Construction

Easy to carry whenever and wherever you need.

# 442 Field Production Mixer

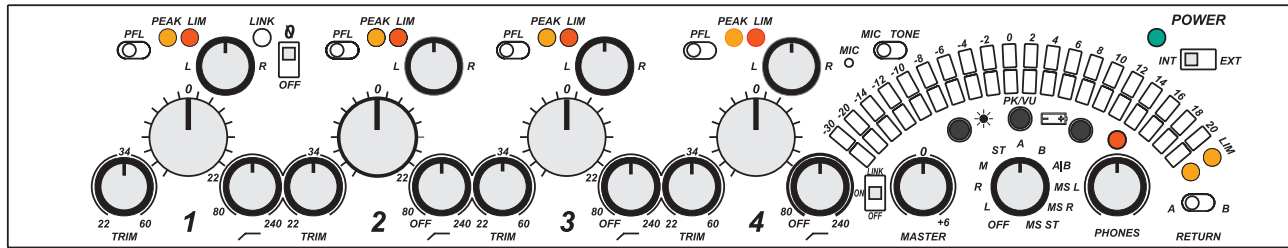

FRONT PANEL

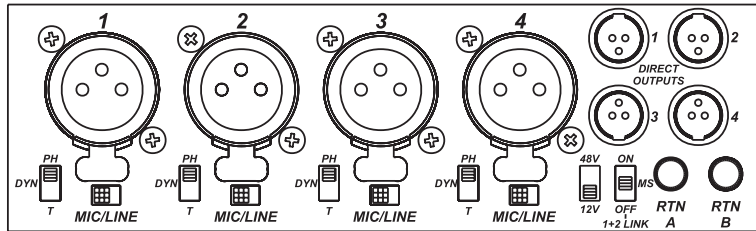

INPUT PANEL

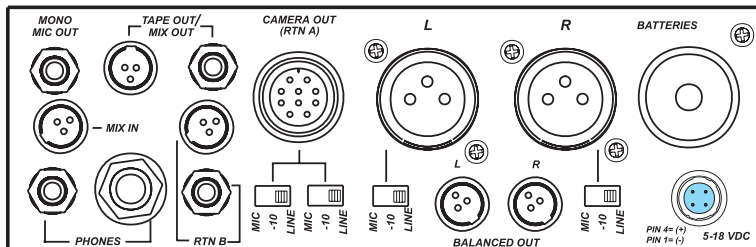

OUTPUT PANEL

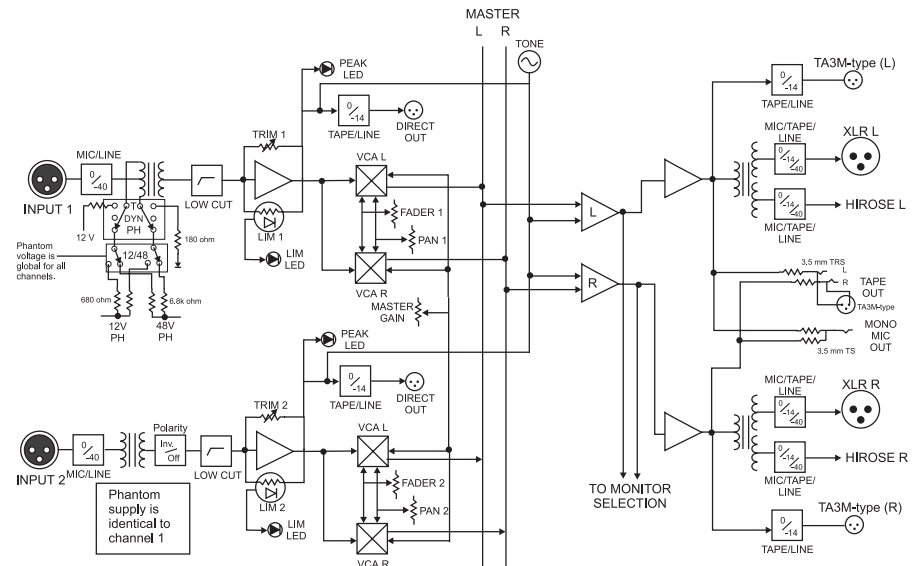

INPUT/OUTPUT BLOCK DIAGRAM



**SOUND DEVICES**

Sound Devices, LLC

300 Wengel Drive, P.O. Box 576

Reedsburg, Wisconsin 53959 USA

tel: (608) 524-0625 fax: (608) 524-0655

® [www.sounddevices.com](http://www.sounddevices.com)